

SINCE 1990



Optional adaptors for Japanese truck.



# H.C.B-C1339

TRUCK KING PIN PRESS (75 TONS)  
DE. PAT.M459081



VIDEO



1. CONTENTS

2 .INTRODUCTION

3.ASEMBLY

## 2 .INTRODUCTION

Transport cart size	L:1120 x W:520 x H:910(mm)
Hydraulic cylinder	75 tons
Stroke	140 mm
Clearance between puller bolts (P.C.D)	300 mm
Clearance height	320mm~430mm
Air Pump	H.C.B-B3036(1800c.c)
Cart Lift	350mm-580mm
Weight	Approx.172kgs

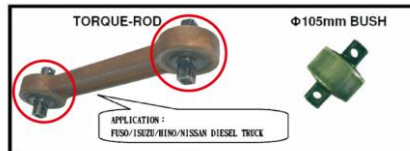

Use with the optional adaptors also remove/ install the torque-rod.

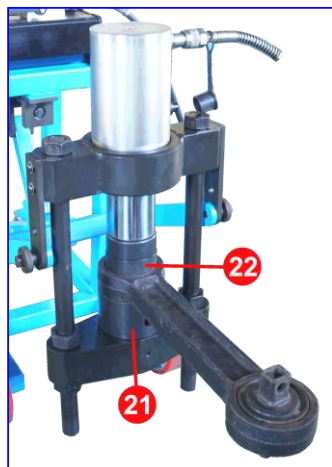

Removal

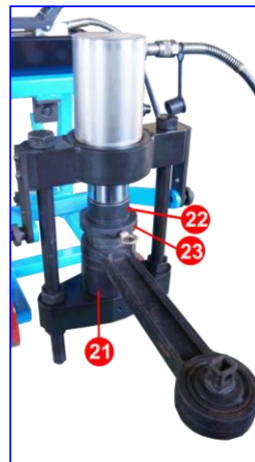

Installation

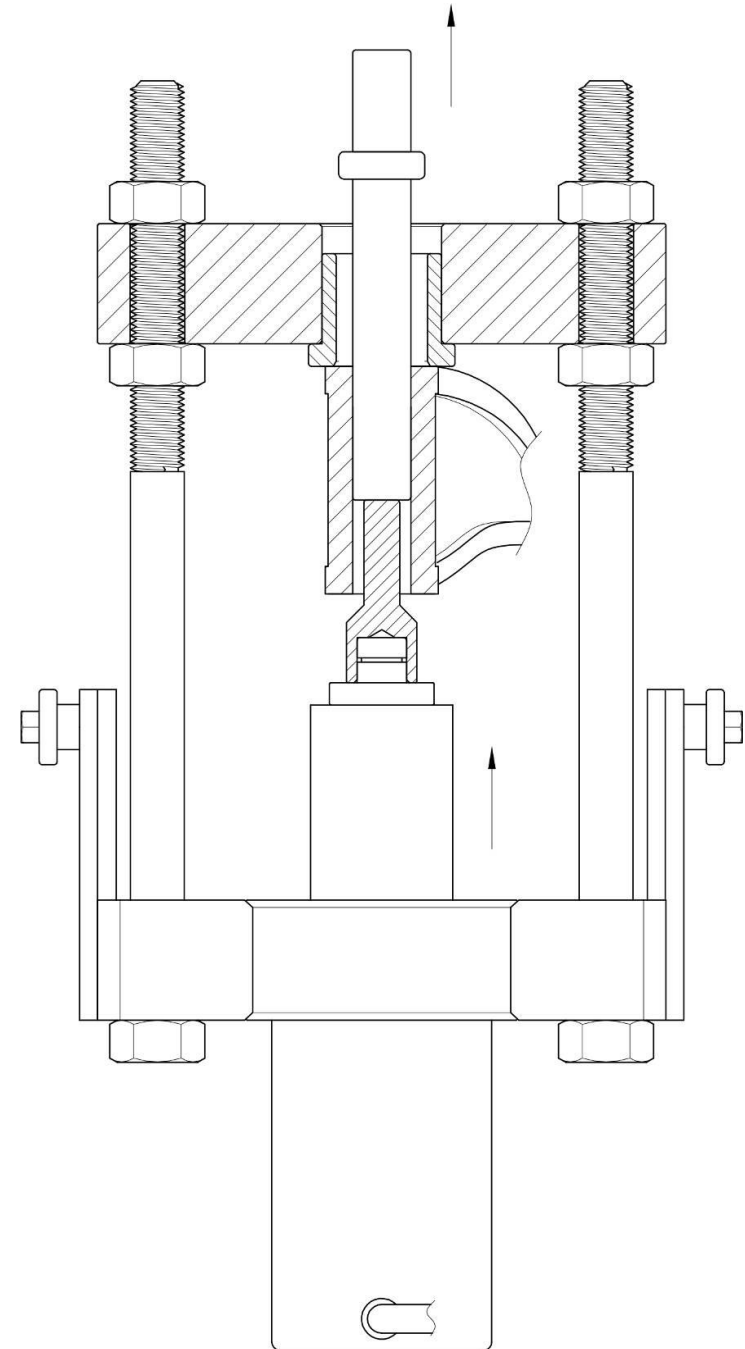

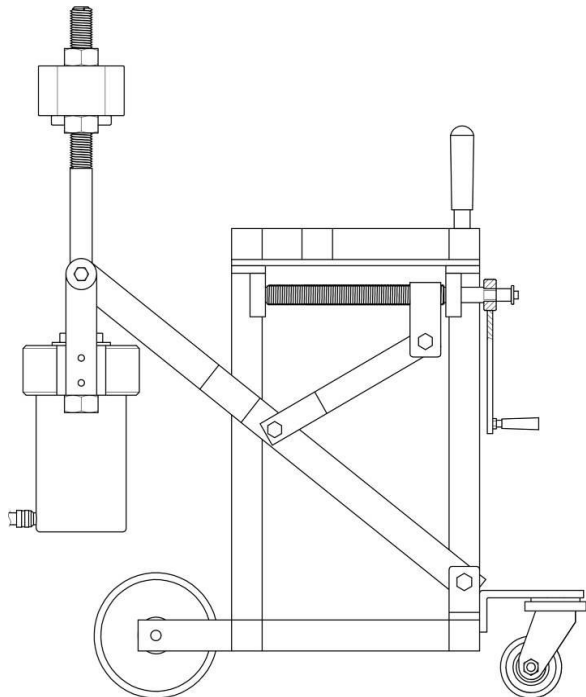
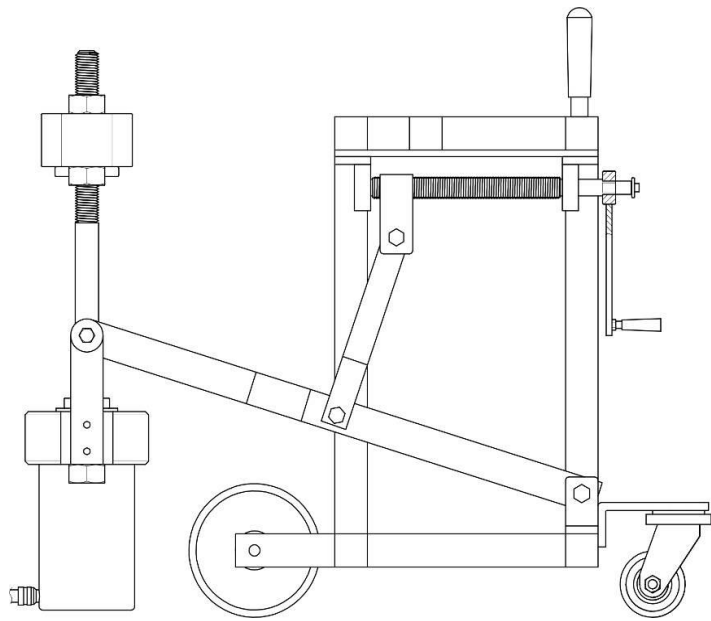

### Reason for replacing King Pin bearing:

King Pin bearing will loosen after driving long-term period and this will cause front wheel alignment problem and it would be dangerous to drivers.

### Description:

1. This press can assemble and disassemble KING PIN on European trucks and Japanese trucks for replacing bearing or sleeve.
2. Save time , labor and money!
3. With the revised bar, you can turn it 360° .

### Product features:

Flexibility at work.

It can be upwards and downwards (rotatable 180°) depends on position of King pin when assembly or disassembly.

With 75 tons hydraulic cylinder & B3036 pump (1800 c.c.)

Application: European trucks & Japanese trucks.

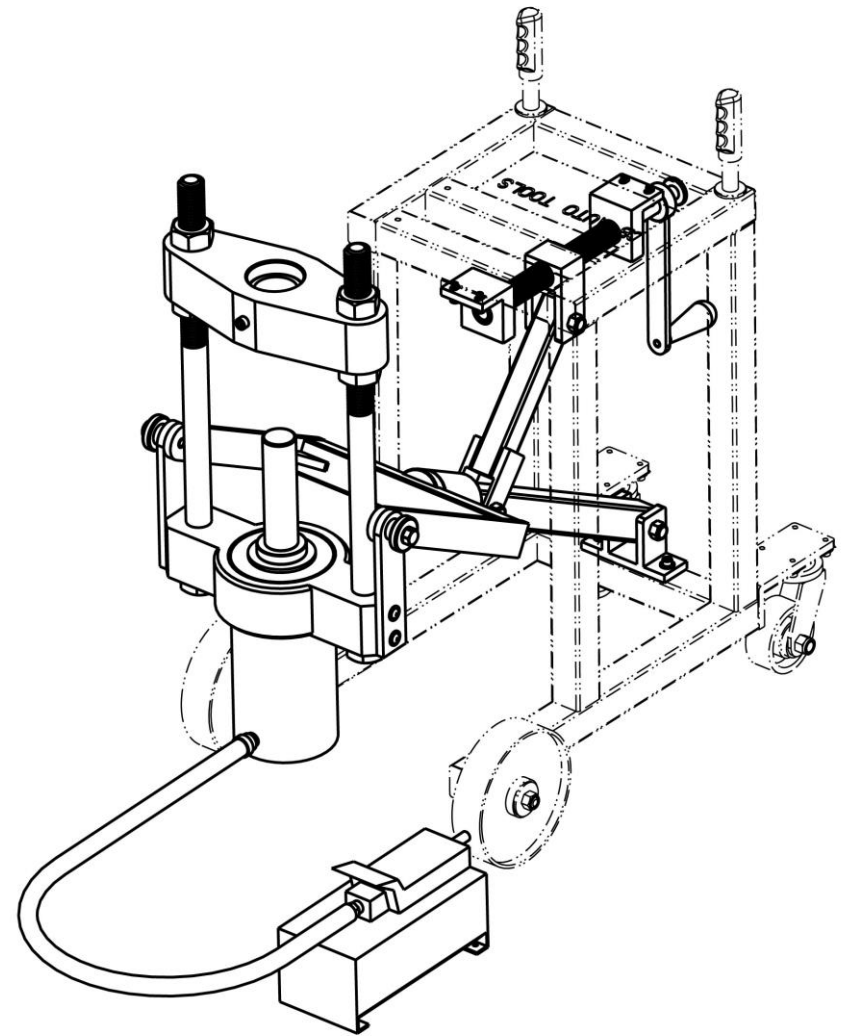
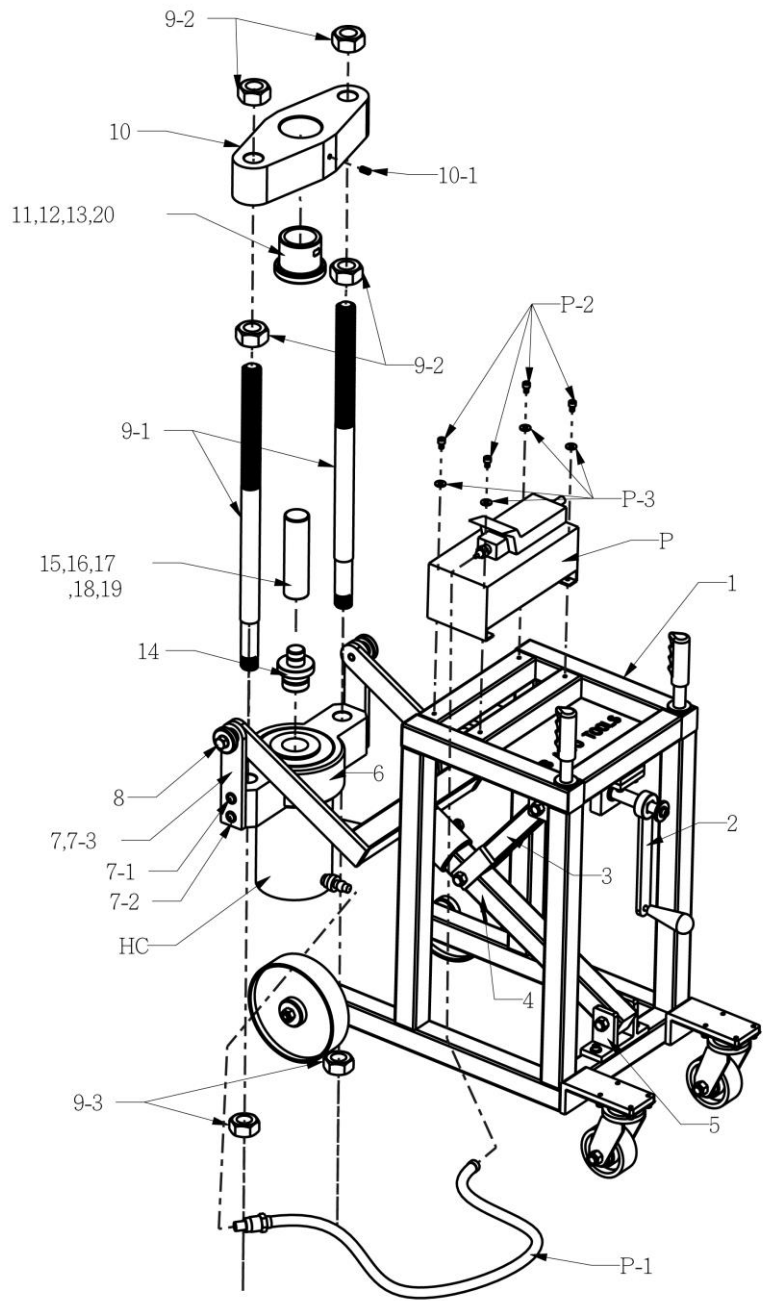

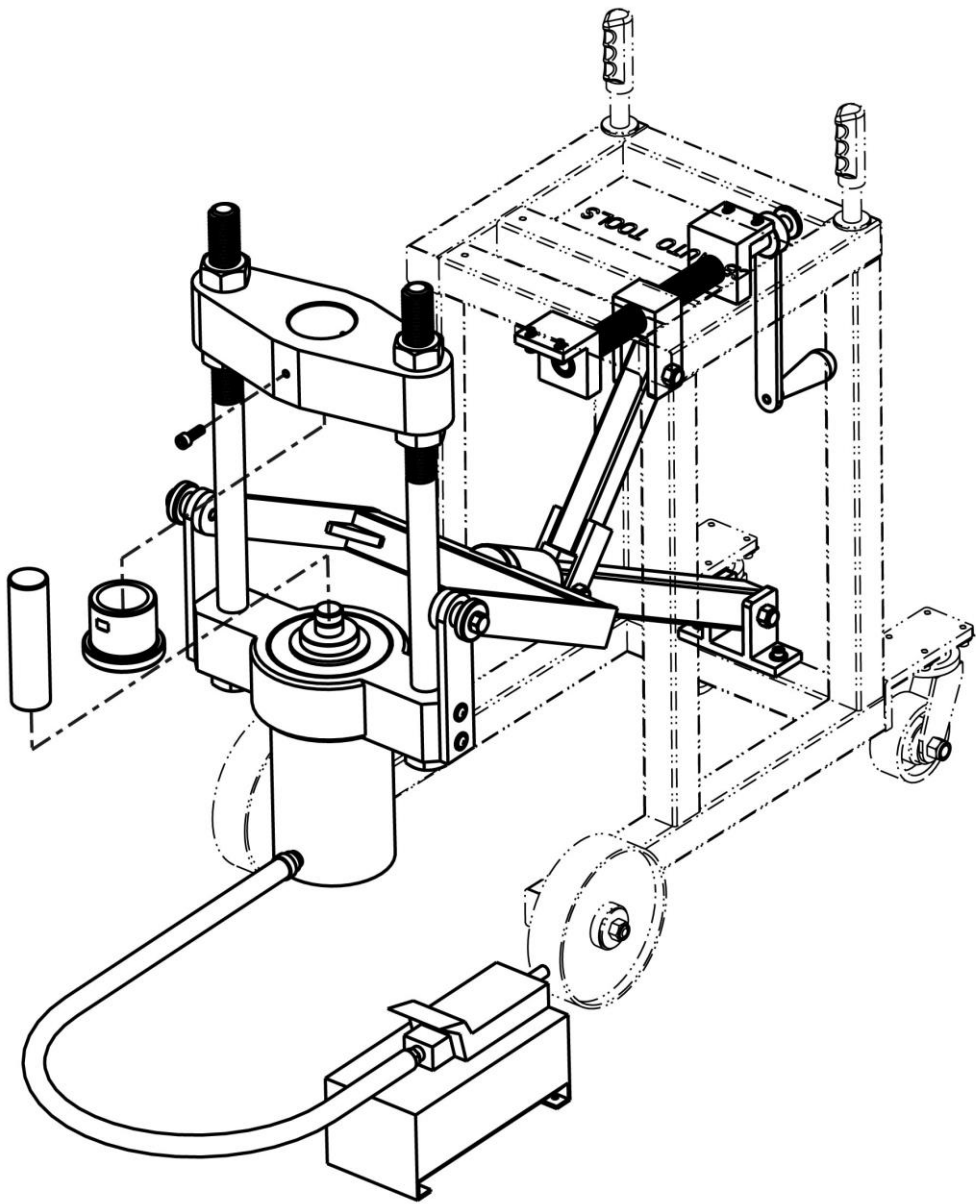

(11)

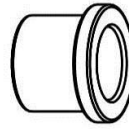

(12)

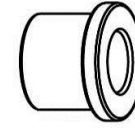

(13)

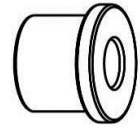

(14)

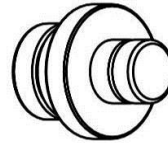

(15)

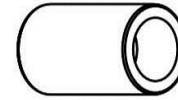

(16)

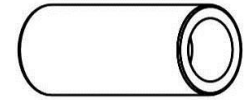

(17)



(18)

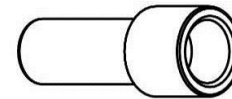

(19)

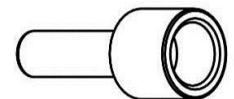

(20)

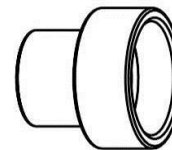

(7)

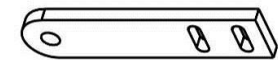

(7-3)

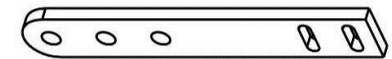

Item No.	DESCRIPTION	SPECIFICATION	Q'TY	
1	Trolley	L794xW410xH835	1	t4
2	Handle bar	L248xW50xH106	1	φ 20x20L
3	Lift connecting rod	L318xW64xH40	1	t4
4	Lifting arm	L931.5xW379xH80	1	t4
5	Lifting arm base	L50xW150xH86	1	
6	Cylinder base	φ190x80L	1	M146xP2.5x60L
7	Connecting arm	L50xW12xH220	2	
7-1	Socket button head screws	M10xP1.5x30L	4	
7-2	Washer	M10xt1.5	4	D : φ21
7-3	Connecting arm	L50xW12xH320	2	
8	Fixing Bolt	φ50x63L	2	
9-1	Bolts	φ36x650L	2	
9-2	Nuts	M36xP4.0x28L	4	H54
9-3	Nuts	M33xP3.5x25L	2	H50
10	Upper base	L140xW380xH80	1	
10-1	Set screws	M10xP1.5x20L	1	
11	Support sleeve	φ98x75L	1	d : φ61
12	Support sleeve	φ98x75L	1	d : φ51
13	Support sleeve	φ98x75L	1	d : φ40
14	Remove Mandrel adaptor	φ70x80L	1	
15	Remove Mandrel	φ47x80L	1	d : φ33x30L
16	Remove Mandrel	φ47x120L	1	d : φ33x30L
17	Remove Mandrel	φ47x170L	1	d : φ33x30L
18	Remove Mandrel	φ47x126.5L	1	d : φ33x30L
19	Remove Mandrel	φ47x121.5L	1	d : φ33x30L
20	Remove sleeve	φ117x110L	1	
HC	Hydraulic cylinder (75tons)	φ146x295L	1	
P	Air pump	L140xW305xH203	1	
P-1	Oil tube	3/8" NPTx1800	1	
P-2	Hex Socket Screws	M8xP1.25x20L	4	
P-3	Washer	M8xt1.5	4	D : φ20

### 3.ASSEMBLY

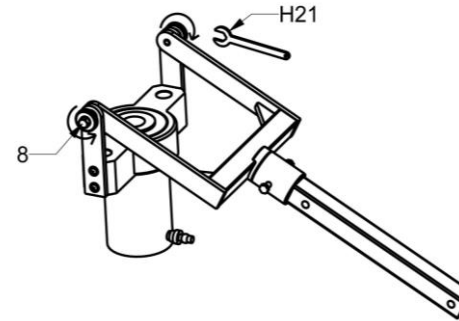

1. To make hydraulic cylinder adjust position, use 21H wrench and turn anti-clockwise on part number 8 until loosen.

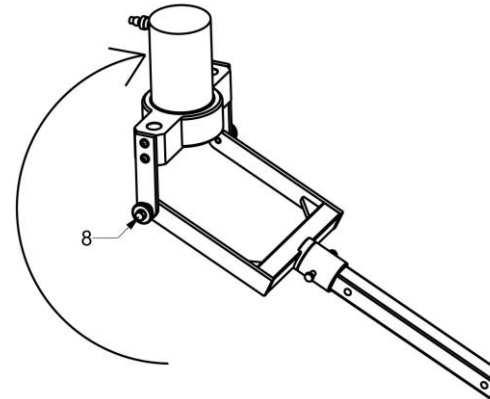

2. And then put hydraulic cylinder to work position.

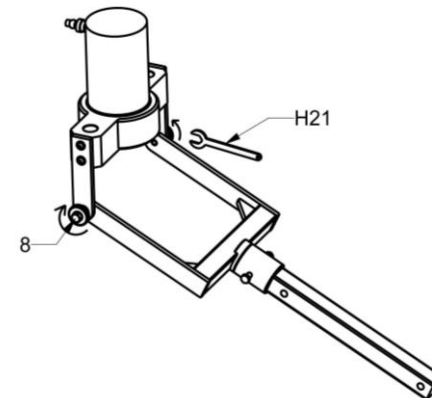

3. Finally, use 21H wrench and turn clockwise to tighten on part number 8 to make cylinder fix on the appropriate work position.